

## SportCruiser Pricelist 2011 Europe



### SportCruiser exclusive distributor:

**LETOV AIR GROUP s.r.o.**

Showroom:  
Airfield Kolín (LKKO)  
280 02 Kolín  
Czech Republic

letovair@letovair.cz  
www.letovair.cz

## Aircraft general description

The SportCruiser is a double seater aircraft of metal construction. The aircraft is arranged as a low wing mono-plane with cantilevered wings and a conventional empennage. The aircraft incorporates a tricycle landing gear.

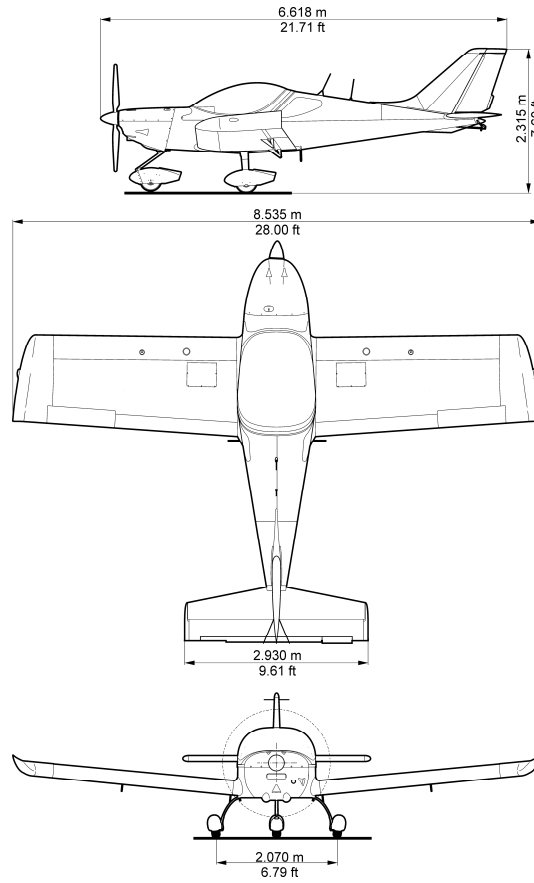

MTOW 600 Kg  
Cruising speed 100 Kts

## Czech Sport Aircraft SportCruiser Permit to Fly Pricelist 2011 Europe

With the publication of this pricelist, previous editions are superseded.  
All prices excluding VAT and customs; FCA Kunovice, Czech Republic.

### ***Features (all models)***

#### **Powerplant**

- ROTAX 912 ULS (74 kW / 100 HP)
- Gearbox with Overload Protection Clutch
- Stainless Steel Exhaust System
- Airbox with Carburetor Heat
- Vapor Lock Vent and Return Line (essential for MOGAS operation in hot or high altitude conditions)
- Woodcomp Klassic 3 Blade Propeller (Composite, ground adjustable)

#### **Standard Airframe Features**

- Locking Canopy
- Dual Sticks
- Individually In-Flight Adjustable Rudder Pedals
- 4-point Seatbelts
- Large Baggage Area
- Wing Lockers
- Wing Tanks 2 x 57 l
- Locking Fuel Caps
- Electric Aileron Trim
- Electric Pitch Trim
- Trim Control and PTT on both Control Sticks
- Electric Flaps with LED Position Display
- Hydraulic Brakes, Dual Foot-tip Brake Pedals
- Parking Brake
- Wheel Fairings
- Corrosion Protection
- Tow Bar
- Lighting package (Strobe and NAV lights in wing tips, Landing light in lower engine cowl)
- Canopy Sunshade

## **SportCruiser Classic**

### **Instruments (Analogue 6-pack)**

- Airspeed Indicator
- Altimeter
- Directional Gyro
- Turn and Bank Coordinator
- Artificial horizon
- Vertical Speed Indicator
- Magnetic Compass on the Glareshield
- Oil Pressure Indicator
- Oil Temperature Indicator
- RPM Indicator
- Cylinder Head (Water) Temperature
- Voltmeter
- Fuel Gauges (left and right tank)
- Fuel Pressure indicator
- Hour Meter (Hobbs)
- Pitch Trim Indicator (LED)
- Aileron Trim indicator (LED)

### **Warning Lights**

- Generator Warning Light (red)
- Fuel Pump On (green)

### **Avionics**

- Garmin SL40 COM
- Garmin GTX 328 Transponder, Mode S, Class 2, with Blind Encoder and Antenna
- Garmin Aera 500 GPS
- PS Engineering Stereo Intercom with MP3 Input
- AmeriKing 406/121.5/243 MHz ELT, Panel Indicator
- 12V Outlet Automotive Jack

### **Airframe Features**

- One tone paint (white airframe, color of the stripe on customer's choice)
- Leather upholstery

<b>SportCruiser Classic</b>	75 000 €
-----------------------------	----------

## **SportCruiser Classic Plus**

### **Instruments (Analogue 6-pack)**

- Airspeed Indicator
- Altimeter
- Directional Gyro
- Course Deviation Indicator
- Turn and Bank Coordinator
- Artificial horizon
- Vertical Speed Indicator
- Magnetic Compass on the Glareshield
- Oil Pressure Indicator
- Oil Temperature Indicator
- RPM Indicator
- Cylinder Head (Water) Temperature
- Voltmeter
- Fuel Gauges (left and right tank)
- Fuel Pressure indicator
- Hour Meter (Hobbs)
- Pitch Trim Indicator (LED)
- Aileron Trim indicator (LED)

### **Warning Lights**

- Generator Warning Light (red)
- Fuel Pump On (green)

### **Avionics**

- Garmin SL30 COM
- Garmin GTX 328 Transponder, Mode S, Class 2, with Blind Encoder and Antenna
- Garmin AERA 500 GPS
- PS Engineering Stereo Intercom with MP3 Input
- AmeriKing 406/121.5/243 MHz ELT, Panel Indicator
- 12V Outlet Automotive Jack

### **Airframe Features**

- One tone paint (white airframe, color of the stripe on customer's choice)
- Matching leather upholstery

<b>SportCruiser Classic Plus</b>	79 990 €
----------------------------------	----------

## **SportCruiser Glass Cockpit**

### **Instruments**

- Dynon EFIS-D100, bright screen
- Dynon EMS-D120 (with fuel flow), bright screen
- Dynon Standby Battery
- OAT probe
- Backup Airspeed Indicator, single hand 2 ¼"
- Backup Altimeter, single hand, 2 ¼"
- Magnetic Compass on the Glareshield
- Pitch Trim Indicator on EFIS
- Aileron Trim Indicator on EFIS

### **Warning Lights**

- EFIS Warning Light (red)
- Fuel Pump On (green)

### **Avionics**

- Garmin SL40 COM
- Garmin GTX 328 Transponder, Mode S, Class 2, Encoder Data from EFIS, Antenna
- Garmin AERA 500
- PS Engineering Stereo Intercom with MP3 Input
- AmeriKing 406/121.5/243 MHz ELT, Panel Indicator
- 12V Outlet Automotive Jack

### **Airframe Features**

- Two-tone Paint, Matching Upholstery (Textile or Leather)

<b>SportCruiser Glass Cockpit</b>	75 000 €
-----------------------------------	----------

## **SportCruiser Glass Cockpit Plus**

### **Instruments**

- Dynon EFIS-D100, bright screen
- Dynon EMS-D120 (with fuel flow), bright screen
- Dynon Standby Battery
- OAT probe
- Backup Airspeed Indicator, single hand 2 ¼"
- Backup Altimeter, single hand, 2 ¼"
- Magnetic Compass on the Glareshield
- Pitch Trim Indicator on EFIS
- Aileron Trim Indicator on EFIS

### **Warning Lights**

- EFIS Warning Light (red)
- Fuel Pump On (green)

### **Avionics**

- Dynon Autopilot AP74+ HS34
- Garmin SL30 COM
- Garmin GTX 328 Transponder, Mode S, Class 2, Encoder Data from EFIS, Antenna
- Garmin AERA 500
- PS Engineering Stereo Intercom with MP3 Input
- AmeriKing 406/121.5/243 MHz ELT, Panel Indicator
- 12V Outlet Automotive Jack

### **Airframe Features**

- Two-tone Paint, Matching Upholstery (Textile or Leather)

<b>SportCruiser Glass Cockpit Plus</b>	89 900 €
--	----------

## Options

### Powerplant

Woodcomp SR3000/2 Two Blade Variable Pitch Propeller, Constant Speed Controller, Manifold Pressure Gauge (Upgrade from Standard Propeller)	3500 €
--	--------

### Airframe

BRS System	4200 €
Bronze canopy	300 €
Extra cushion	120 €/pc
Two tone paint (for Classic models only)	3250 €

### Panel Options and Upgrades

Vertical Card Compas (PAI 700)	310 €
--------------------------------	-------

### Avionics Standard, Options and Upgrades

Garmin GPSMAP 695 (Upgrade from Garmin AERA 500) for Glass cockpit model only	1000 €
Garmin GPS AERA 510 (Upgrade from Garmin AERA 500)	1450 €

### Covers

Cover for Engine and Canopy (1pc)	105 €
Splitted Cover for Engine and Canopy (1pc for Engine, 1pc for Canopy)	158 €
Complete aircraft cover for outdoor parking	1050 €